

# Diesel Systems

## Common Rail Systems CRS3 with 1,800 to 2,000 bar and piezo injectors



**BOSCH**

Invented for life

### Common Rail System CRS3-20

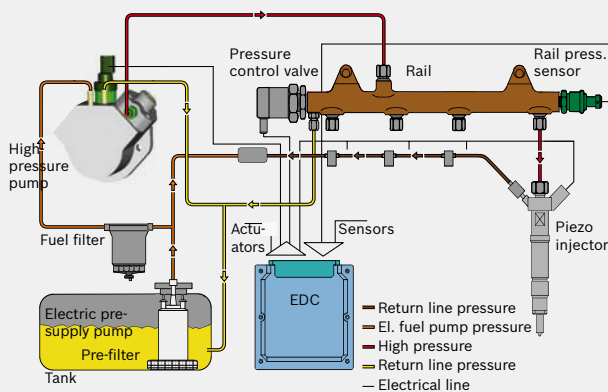

#### Customer benefits

- ▶ High mileage with stable injection quantity
- ▶ Very robust system, even for critical fuel qualities
- ▶ Efficient and versatile due to modular system design: for engines with 4 to 12 cylinders
- ▶ Reduced emissions and combustion noise due to reduced hydraulic flow rate
- ▶ High hydraulic efficiency due to injectors without permanent leakage which leads to lower fuel temperature
- ▶ Efficient and fuel-saving in part due to start/stop compatibility
- ▶ Many years of system experience
- ▶ Increased flexibility for basic engine design and application of exhaust-gas treatment

Fuel consumption is an important economic factor for the market success of a vehicle; the higher the mileage, the more so. Emissions, operating noise and engine power characteristics are also important. The modern Common Rail Systems CRS3-18 (with 1,800 bar) and CRS3-20 (with 2,000 bar) allow engines to be designed with ideal properties thanks to their piezo injectors.

Varying fuel qualities are a challenge for every injection system. With the robust piezo actuator the injectors of the CRS3-18/20 are perfectly suited. Compared with a solenoid, the power of the piezo actuator is about ten times as high. This means it is less susceptible to small particle contamination in the fuel.

CRS3-18 and -20 piezo injectors are benchmarks regarding minimum pilot-injection quantity, fast succession of injections and volume stability over the lifetime.

Since the piezo actuator is integrated into the injector body, piezo injectors are slim and need less installation space than solenoid injectors.

#### Possible applications

CRS3-18 and CRS3-20 are used in the highest performance passenger cars and light-duty vehicles.

### Technical features

Engine cylinders	4...12
Max. system pressure	1,800/2,000 bar
Max. number of injections	8
Min. injection separation time	200 µs
Operating voltage	12 V/24 V
Emission target	Euro 5, Euro 6, T2B5, US10, JPNLT
Service life PC/LD	300,000/400,000 km
Applications	PC, LD

### System components

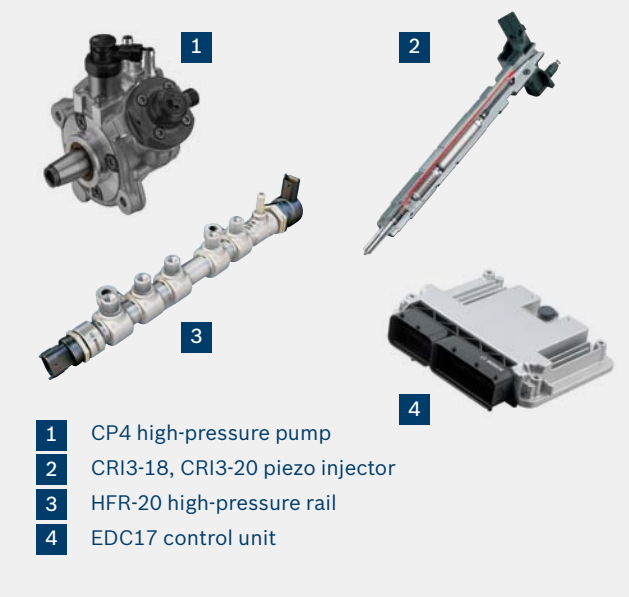

### System design and function

The piezo actuator delivers multiple injections with minimal intervals. The interaction between the actuator and the nozzle needle helps to achieve shortest possible reaction times.

Optimized injector characteristics without plateaus allow fuel quantity correction over lifetime by means of learning functions. These are implemented as software in the electronic control unit.

The system consists of a high-pressure pump, the high-pressure rail, an injector for each engine cylinder, and the electronic control.

Thanks to their high switching speed the CRS3-18/-20 piezo injectors enable very small pilot-injection quantities. Because reduced hydraulic power loss reduces fuel temperature, no additional fuel cooling is required.

The HFR-20 high-pressure rail features drilled throttles, a rail pressure sensor and a pressure-control valve.

The CP4 high-pressure pump's high hydraulic efficiency leads to a high delivery rate, easily covering all requirements up to light-duty applications.

### Outlook

Bosch engineers are already involved in the further development of this system by increasing pressure to 2,500 bar with even shorter intervals between injections.

### Bosch: Automotive competence from a single source



Comprehensive range of services and know-how



System and network competence



Innovator and technology leader



Warrantor for quality and dependability



Worldwide presence



Universal partner

**Robert Bosch GmbH**  
 Diesel Systems

Postfach 30 02 20  
 70442 Stuttgart  
 Germany  
 Fax: +49 711 811-45090  
 diesel@bosch.com

[www.bosch-diesel.de](http://www.bosch-diesel.de)

Printed in Germany  
 292000P0PLC/CCA-201108-En